

NEW



**80
Super**

The perfect **LED** upgrade from flourescent dome lighting



SPECS

Weight : <2 Pounds
 Harness Length : 6", blunt cut 14 AWG SXL wire
 Light Source : 10 White LED's
 Operating Voltage : 7V-16V
 Current draw : 2A
 Power Consumption : 22Watt@11v

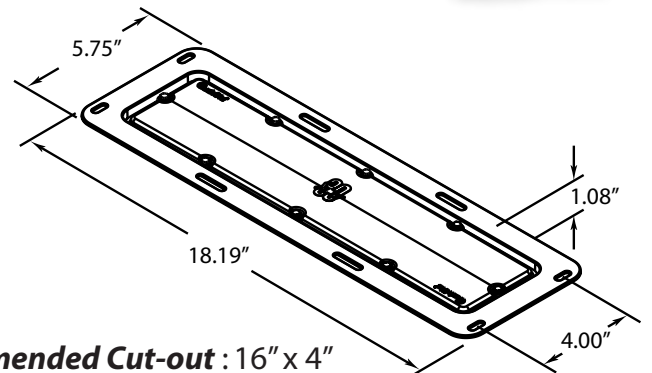

Recommended Cut-out : 16" x 4"

FEATURES

- Die Cast Aluminum Housing
- White Powder Coat Finish
- Polycarbonate Lens
- 10 White 1Watt LED's
- Lower profile than competitive lamps (will mount in 1" deep pocket)
- Nearly flush mount, only .1" protrusion

BENEFITS

- Not affected by cold temperatures
- LED's provide whiter, brighter light
- Retrofit or replacement is quick and easy
- Flicker free lighting in all temperatures
- Truck-Lite Limited Lifetime Warranty

PART	DESCRIPTION	QTY.
80251C	Super 80® LED Interior Lamp	1

